

13 May 2026

Chief Executive Officer
Douglas Shire Council
PO Box 723
Mossman Qld 4873

Attention: Development Assessment

Dear Sir/Madam

RE: APPLICATION FOR DEVELOPMENT PERMIT – Building Works– Shed – 256 Bamboo Creek Road Bamboo, Lot 3 on RP865065

Rapid Building Approvals acting on behalf of the owners of the abovementioned land (Russell Duncan) we seek a **Development Permit for Building Works (Shed) at 256 Bamboo Creek Road Bamboo, Lot 3 on RP865065**

The property is zoned Environmental Management, within the planning scheme identifying a Building works as code assessable.

Applicable Code	Compliance	Comment
Environmental Management Zone	<input checked="" type="checkbox"/>	Complies. Refer to the code assessment.
Acid Sulfate Soils Overlay (5-20m AHD)	<input checked="" type="checkbox"/>	Complies. The proposal can comply with the requirements of the code.
Floodplain Assessment Overlay (Daintree River)	<input checked="" type="checkbox"/>	Complies. The proposal is for a non-habitable building.
Excavation and Filling	<input checked="" type="checkbox"/>	Complies. No significant excavation and filling is required for the shed. Proposal can comply with all other aspects of the code.
Infrastructure Works	<input checked="" type="checkbox"/>	Complies. Proposal is for a shed and all the required infrastructure can be accommodated.

In support of this development application, the following material has been provided:

1. DA Form 1 and 2
2. Plans
3. Response to relevant Planning Scheme Codes
4. Application fee

Should you require any further information or assistance in relation to this manner please don't hesitate to contact Scott Wheeler on [1300 163 814](tel:1300163814) or via email at approvals@rapidapprovals.com.au.

Regards,

Scott Wheeler

Code Responses

Environmental Management Zone Code

Performance outcomes	Acceptable outcomes	Applicant response
For self-assessable and assessable development		
<p>PO1 The height of all buildings and structures is in keeping with the natural characteristics of the site. Buildings and structures are low-rise and not unduly visible from external sites.</p>	<p>AO1.1 Buildings and structures are not more than 8.5 metres and two storeys in height. Note – Height is inclusive of the roof height.</p> <p>AO1.2 Buildings have a roof height not less than 2 metres.</p>	<p>Complies. Proposed shed has a maximum height of 3.9 metres.</p>
<p>PO2 Buildings and structures are set back to:</p> <ul style="list-style-type: none"> (a) maintain the natural character of the area; (b) achieve separation from neighbouring buildings and from road frontages. 	<p>AO2 Buildings and structures are set back not less than:</p> <ul style="list-style-type: none"> (a) 40 metres from the frontage of a state controlled road; (b) 25 metres from the frontage to Cape Tribulation Road; (c) 6 metres from any other road; (d) 6 metres from the side and rear boundaries of the site. 	<p>Complies PO2. The rear setback for the proposed shed is non-compliant. The location of the proposed shed is to the rear of the property and will not adjoin any structures on the adjoining allotment, which is a rural allotment. It will not be visible from the road frontage, therefore not impacting upon the rural residential character of the area.</p>
For assessable development		
<p>PO3 Development is consistent with the purpose of the Environmental management zone and protects the zone from</p>	<p>AO3 Inconsistent uses as identified in Table 6.2.4.3.b are not established in the Environmental management zone.</p>	<p>Complies. A domestic shed is consistent with the zone.</p>

Performance outcomes	Acceptable outcomes	Applicant response
the intrusion of inconsistent uses.		
<p>PO4 The site coverage of all buildings and structures and associated services do not have an adverse effect on the environmental or scenic values of the site.</p>	<p>PO4 No acceptable outcomes are prescribed.</p>	<p>Complies.</p>
<p>PO5 Development is located, designed, operated and managed to respond to the characteristics, features and constraints of the site and its surrounds.</p> <p>Note - Planning scheme policy – Site assessments provides guidance on identifying the characteristics, features and constraints of a site and its surrounds.</p>	<p>AO5.1 Buildings, structures and associated access, infrastructure and private open space are sited:</p> <p>(a) within areas of the site which are already cleared; or</p> <p>(b) within areas of the site which are environmentally degraded;</p> <p>(c) to minimise additional vegetation clearing.</p>	<p>Complies. The site is cleared.</p>
	<p>AO5.2 Buildings and structures and associated infrastructure are not located on slopes greater than 1 in 6 (16.6%) or on a ridgeline.</p>	<p>Not applicable.</p>
<p>PO6 Buildings and structures are responsive to steep slope through innovative construction techniques so as to:</p> <p>(a) maintain the geotechnical stability of slopes;</p> <p>(b) minimise cut and/or fill;</p> <p>(c) minimise the overall height of development.</p>	<p>AO6.1 Where development on land steeper than 1 in 6 (16.6%) cannot be avoided, development follows the natural contours of the land and single plane concrete slab on-ground methods of construction are not utilised.</p> <p>AO6.2</p>	<p>Not applicable.</p> <p>Complies.</p>

Performance outcomes	Acceptable outcomes	Applicant response
	<p>Access and vehicle manoeuvring and parking areas are constructed and maintained to:</p> <ul style="list-style-type: none"> (a) minimise erosion; (b) minimise cut and fill; (c) follow the natural contours of the site. 	
<p>PO7 The exterior finishes of buildings and structures are consistent with the surrounding natural environment.</p>	<p>PO7 The exterior finishes and colours of buildings and structures are non-reflective and are moderately dark to darker shades of grey, green, blue and brown or the development is not visible external to the site.</p>	<p>Complies. The proposed shed will be feature colorbond cladding and will not be visible from the road frontage.</p>
<p>PO8 Development does not adversely affect the amenity of the zone and adjoining land uses in terms of traffic, noise, dust, odour, lighting or other physical or environmental impacts.</p>	<p>AO8 No acceptable outcomes are prescribed.</p>	<p>Complies. Proposal is for a shed and will not result in any adverse impacts to adjoining allotments.</p>
<p>PO9 The density of development ensures that the environmental and scenic amenity values of the site and surrounding area are not adversely affected.</p>	<p>AO9 The maximum residential density is one dwelling house per lot.</p>	<p>Complies.</p>
<p>PO10 Lot reconfiguration results in no additional lots. Note - Boundary realignments to resolve encroachments and lot amalgamation are considered appropriate.</p>	<p>AO10 No acceptable outcomes are prescribed.</p>	<p>Not applicable.</p>

DA Form 1 – Development application details

Approved form (version 1.6 effective 2 August 2024) made under section 282 of the Planning Act 2016.

This form **must** be used to make a development application **involving code assessment or impact assessment**, except when applying for development involving only building work.

For a development application involving **building work only**, use *DA Form 2 – Building work details*.

For a development application involving **building work associated with any other type of assessable development (i.e. material change of use, operational work or reconfiguring a lot)**, use this form (*DA Form 1*) and parts 4 to 6 of *DA Form 2 – Building work details*.

Unless stated otherwise, all parts of this form **must** be completed in full and all required supporting information **must** accompany the development application.

One or more additional pages may be attached as a schedule to this development application if there is insufficient space on the form to include all the necessary information.

This form and any other form relevant to the development application must be used to make a development application relating to strategic port land and Brisbane core port land under the *Transport Infrastructure Act 1994*, and airport land under the *Airport Assets (Restructuring and Disposal) Act 2008*. For the purpose of assessing a development application relating to strategic port land and Brisbane core port land, any reference to a planning scheme is taken to mean a land use plan for the strategic port land, Brisbane port land use plan for Brisbane core port land, or a land use plan for airport land.

Note: All terms used in this form have the meaning given under the *Planning Act 2016*, the *Planning Regulation 2017*, or the *Development Assessment Rules (DA Rules)*.

PART 1 – APPLICANT DETAILS

1) Applicant details	
Applicant name(s) <i>(individual or company full name)</i>	Russell Duncan
Contact name <i>(only applicable for companies)</i>	Scott Wheeler C/- RAPID Building Approvals
Postal address <i>(P.O. Box or street address)</i>	Suite 7 2-4 Stanton Road
Suburb	Smithfield
State	QLD
Postcode	4878
Country	Australia
Contact number	1300 163 814
Email address <i>(non-mandatory)</i>	approvals@rapidapprovals.com.au
Mobile number <i>(non-mandatory)</i>	
Fax number <i>(non-mandatory)</i>	
Applicant's reference number(s) <i>(if applicable)</i>	2060/26
1.1) Home-based business	
<input type="checkbox"/> Personal details to remain private in accordance with section 264(6) of <i>Planning Act 2016</i>	
2) Owner's consent	
2.1) Is written consent of the owner required for this development application?	
<input type="checkbox"/> Yes – the written consent of the owner(s) is attached to this development application	
<input checked="" type="checkbox"/> No – proceed to 3)	



PART 2 – LOCATION DETAILS

3) Location of the premises (complete 3.1) or 3.2), and 3.3) as applicable)

Note: Provide details below and attach a site plan for any or all premises part of the development application. For further information, see DA Forms Guide: Relevant plans.

3.1) Street address and lot on plan

- Street address **AND** lot on plan (all lots must be listed), **or**
 Street address **AND** lot on plan for an adjoining or adjacent property of the premises (appropriate for development in water but adjoining or adjacent to land e.g. jetty, pontoon. All lots must be listed).

a)	Unit No.	Street No.	Street Name and Type	Suburb
		256	Bamboo Creek Road	Bamboo
	Postcode	Lot No.	Plan Type and Number (e.g. RP, SP)	Local Government Area(s)
	4873	3	RP865065	Douglas Shire Council
b)	Unit No.	Street No.	Street Name and Type	Suburb
	Postcode	Lot No.	Plan Type and Number (e.g. RP, SP)	Local Government Area(s)

3.2) Coordinates of premises (appropriate for development in remote areas, over part of a lot or in water not adjoining or adjacent to land e.g. channel dredging in Moreton Bay)

Note: Place each set of coordinates in a separate row.

- Coordinates of premises by longitude and latitude

Longitude(s)	Latitude(s)	Datum	Local Government Area(s) (if applicable)
		<input type="checkbox"/> WGS84 <input type="checkbox"/> GDA94 <input type="checkbox"/> Other: <input type="text"/>	

- Coordinates of premises by easting and northing

Easting(s)	Northing(s)	Zone Ref.	Datum	Local Government Area(s) (if applicable)
		<input type="checkbox"/> 54 <input type="checkbox"/> 55 <input type="checkbox"/> 56	<input type="checkbox"/> WGS84 <input type="checkbox"/> GDA94 <input type="checkbox"/> Other: <input type="text"/>	

3.3) Additional premises

- Additional premises are relevant to this development application and the details of these premises have been attached in a schedule to this development application
 Not required

4) Identify any of the following that apply to the premises and provide any relevant details

In or adjacent to a water body or watercourse or in or above an aquifer
 Name of water body, watercourse or aquifer:

On strategic port land under the *Transport Infrastructure Act 1994*
 Lot on plan description of strategic port land:
 Name of port authority for the lot:

In a tidal area
 Name of local government for the tidal area (if applicable):
 Name of port authority for tidal area (if applicable):

<input type="checkbox"/> On airport land under the <i>Airport Assets (Restructuring and Disposal) Act 2008</i>
Name of airport: <input type="text"/>
<input type="checkbox"/> Listed on the Environmental Management Register (EMR) under the <i>Environmental Protection Act 1994</i>
EMR site identification: <input type="text"/>
<input type="checkbox"/> Listed on the Contaminated Land Register (CLR) under the <i>Environmental Protection Act 1994</i>
CLR site identification: <input type="text"/>

5) Are there any existing easements over the premises?

Note: Easement uses vary throughout Queensland and are to be identified correctly and accurately. For further information on easements and how they may affect the proposed development, see [DA Forms Guide](#).

- Yes – All easement locations, types and dimensions are included in plans submitted with this development application
- No

PART 3 – DEVELOPMENT DETAILS

Section 1 – Aspects of development

6.1) Provide details about the first development aspect

a) What is the type of development? *(tick only one box)*

- Material change of use Reconfiguring a lot Operational work Building work

b) What is the approval type? *(tick only one box)*

- Development permit Preliminary approval Preliminary approval that includes a variation approval

c) What is the level of assessment?

- Code assessment Impact assessment *(requires public notification)*

d) Provide a brief description of the proposal *(e.g. 6 unit apartment building defined as multi-unit dwelling, reconfiguration of 1 lot into 3 lots):*

Shed

e) Relevant plans

Note: Relevant plans are required to be submitted for all aspects of this development application. For further information, see [DA Forms guide: Relevant plans](#).

- Relevant plans of the proposed development are attached to the development application

6.2) Provide details about the second development aspect

a) What is the type of development? *(tick only one box)*

- Material change of use Reconfiguring a lot Operational work Building work

b) What is the approval type? *(tick only one box)*

- Development permit Preliminary approval Preliminary approval that includes a variation approval

c) What is the level of assessment?

- Code assessment Impact assessment *(requires public notification)*

d) Provide a brief description of the proposal *(e.g. 6 unit apartment building defined as multi-unit dwelling, reconfiguration of 1 lot into 3 lots):*

e) Relevant plans

Note: Relevant plans are required to be submitted for all aspects of this development application. For further information, see [DA Forms Guide: Relevant plans](#).

- Relevant plans of the proposed development are attached to the development application

6.3) Additional aspects of development

- Additional aspects of development are relevant to this development application and the details for these aspects that would be required under Part 3 Section 1 of this form have been attached to this development application
- Not required

6.4) Is the application for State facilitated development?

- Yes - Has a notice of declaration been given by the Minister?
- No

Section 2 – Further development details**7) Does the proposed development application involve any of the following?**

Material change of use Yes – complete division 1 if assessable against a local planning instrument

Reconfiguring a lot Yes – complete division 2

Operational work Yes – complete division 3

Building work Yes – complete *DA Form 2 – Building work details*

Division 1 – Material change of use

Note: This division is only required to be completed if any part of the development application involves a material change of use assessable against a local planning instrument.

8.1) Describe the proposed material change of use

Provide a general description of the proposed use	Provide the planning scheme definition <i>(include each definition in a new row)</i>	Number of dwelling units <i>(if applicable)</i>	Gross floor area (m ²) <i>(if applicable)</i>

8.2) Does the proposed use involve the use of existing buildings on the premises?

Yes

No

8.3) Does the proposed development relate to temporary accepted development under the Planning Regulation?

Yes – provide details below or include details in a schedule to this development application

No

Provide a general description of the temporary accepted development	Specify the stated period dates under the Planning Regulation

Division 2 – Reconfiguring a lot

Note: This division is only required to be completed if any part of the development application involves reconfiguring a lot.

9.1) What is the total number of existing lots making up the premises?**9.2) What is the nature of the lot reconfiguration? *(tick all applicable boxes)***

Subdivision *(complete 10)*

Dividing land into parts by agreement *(complete 11)*

Boundary realignment *(complete 12)*

Creating or changing an easement giving access to a lot from a constructed road *(complete 13)*

14.3) What is the monetary value of the proposed operational work? (include GST, materials and labour)

\$

PART 4 – ASSESSMENT MANAGER DETAILS

15) Identify the assessment manager(s) who will be assessing this development application

Douglas Shire Council

16) Has the local government agreed to apply a superseded planning scheme for this development application?

- Yes – a copy of the decision notice is attached to this development application
- The local government is taken to have agreed to the superseded planning scheme request – relevant documents attached
- No

PART 5 – REFERRAL DETAILS

17) Does this development application include any aspects that have any referral requirements?

Note: A development application will require referral if prescribed by the Planning Regulation 2017.

- No, there are no referral requirements relevant to any development aspects identified in this development application – proceed to Part 6

Matters requiring referral to the **Chief Executive of the Planning Act 2016:**

- Clearing native vegetation
- Contaminated land (*unexploded ordnance*)
- Environmentally relevant activities (ERA) (*only if the ERA has not been devolved to a local government*)
- Fisheries – aquaculture
- Fisheries – declared fish habitat area
- Fisheries – marine plants
- Fisheries – waterway barrier works
- Hazardous chemical facilities
- Heritage places – Queensland heritage place (*on or near a Queensland heritage place*)
- Infrastructure-related referrals – designated premises
- Infrastructure-related referrals – state transport infrastructure
- Infrastructure-related referrals – State transport corridor and future State transport corridor
- Infrastructure-related referrals – State-controlled transport tunnels and future state-controlled transport tunnels
- Infrastructure-related referrals – near a state-controlled road intersection
- Koala habitat in SEQ region – interfering with koala habitat in koala habitat areas outside koala priority areas
- Koala habitat in SEQ region – key resource areas
- Ports – Brisbane core port land – near a State transport corridor or future State transport corridor
- Ports – Brisbane core port land – environmentally relevant activity (ERA)
- Ports – Brisbane core port land – tidal works or work in a coastal management district
- Ports – Brisbane core port land – hazardous chemical facility
- Ports – Brisbane core port land – taking or interfering with water
- Ports – Brisbane core port land – referable dams
- Ports – Brisbane core port land – fisheries
- Ports – Land within Port of Brisbane's port limits (*below high-water mark*)
- SEQ development area
- SEQ regional landscape and rural production area or SEQ rural living area – tourist activity or sport and recreation activity
- SEQ regional landscape and rural production area or SEQ rural living area – community activity
- SEQ regional landscape and rural production area or SEQ rural living area – indoor recreation
- SEQ regional landscape and rural production area or SEQ rural living area – urban activity
- SEQ regional landscape and rural production area or SEQ rural living area – combined use
- SEQ northern inter-urban break – tourist activity or sport and recreation activity



- SEQ northern inter-urban break – community activity
- SEQ northern inter-urban break – indoor recreation
- SEQ northern inter-urban break – urban activity
- SEQ northern inter-urban break – combined use
- Tidal works or works in a coastal management district
- Reconfiguring a lot in a coastal management district or for a canal
- Erosion prone area in a coastal management district
- Urban design
- Water-related development – taking or interfering with water
- Water-related development – removing quarry material (*from a watercourse or lake*)
- Water-related development – referable dams
- Water-related development – levees (*category 3 levees only*)
- Wetland protection area

Matters requiring referral to the local government:

- Airport land
- Environmentally relevant activities (ERA) (*only if the ERA has been devolved to local government*)
- Heritage places – Local heritage places

Matters requiring referral to the Chief Executive of the distribution entity or transmission entity:

- Infrastructure-related referrals – Electricity infrastructure

Matters requiring referral to:

- The **Chief Executive of the holder of the licence**, if not an individual
- The **holder of the licence**, if the holder of the licence is an individual
- Infrastructure-related referrals – Oil and gas infrastructure

Matters requiring referral to the Brisbane City Council:

- Ports – Brisbane core port land

Matters requiring referral to the Minister responsible for administering the Transport Infrastructure Act 1994:

- Ports – Brisbane core port land (*where inconsistent with the Brisbane port LUP for transport reasons*)
- Ports – Strategic port land

Matters requiring referral to the relevant port operator, if applicant is not port operator:

- Ports – Land within Port of Brisbane’s port limits (*below high-water mark*)

Matters requiring referral to the Chief Executive of the relevant port authority:

- Ports – Land within limits of another port (*below high-water mark*)

Matters requiring referral to the Gold Coast Waterways Authority:

- Tidal works or work in a coastal management district (*in Gold Coast waters*)

Matters requiring referral to the Queensland Fire and Emergency Service:

- Tidal works or work in a coastal management district (*involving a marina (more than six vessel berths)*)

18) Has any referral agency provided a referral response for this development application?

- Yes – referral response(s) received and listed below are attached to this development application
- No

Referral requirement	Referral agency	Date of referral response

Identify and describe any changes made to the proposed development application that was the subject of the referral response and this development application, or include details in a schedule to this development application (*if applicable*).

PART 6 – INFORMATION REQUEST

19) Information request under the DA Rules

- I agree to receive an information request if determined necessary for this development application
 I do not agree to accept an information request for this development application

Note: By not agreeing to accept an information request I, the applicant, acknowledge:

- that this development application will be assessed and decided based on the information provided when making this development application and the assessment manager and any referral agencies relevant to the development application are not obligated under the DA Rules to accept any additional information provided by the applicant for the development application unless agreed to by the relevant parties
- Part 3 under Chapter 1 of the DA Rules will still apply if the application is an application listed under section 11.3 of the DA Rules or
- Part 2 under Chapter 2 of the DA Rules will still apply if the application is for state facilitated development

Further advice about information requests is contained in the [DA Forms Guide](#).

PART 7 – FURTHER DETAILS

20) Are there any associated development applications or current approvals? (e.g. a preliminary approval)

- Yes – provide details below or include details in a schedule to this development application
 No

List of approval/development application references	Reference number	Date	Assessment manager
<input type="checkbox"/> Approval <input type="checkbox"/> Development application			
<input type="checkbox"/> Approval <input type="checkbox"/> Development application			

21) Has the portable long service leave levy been paid? (only applicable to development applications involving building work or operational work)

- Yes – a copy of the receipted QLeave form is attached to this development application
 No – I, the applicant will provide evidence that the portable long service leave levy has been paid before the assessment manager decides the development application. I acknowledge that the assessment manager may give a development approval only if I provide evidence that the portable long service leave levy has been paid
 Not applicable (e.g. building and construction work is less than \$150,000 excluding GST)

Amount paid	Date paid (dd/mm/yy)	QLeave levy number (A, B or E)
\$\$ 0.00		

22) Is this development application in response to a show cause notice or required as a result of an enforcement notice?

- Yes – show cause or enforcement notice is attached
 No

23) Further legislative requirements

Environmentally relevant activities

23.1) Is this development application also taken to be an application for an environmental authority for an **Environmentally Relevant Activity (ERA)** under section 115 of the *Environmental Protection Act 1994*?

- Yes – the required attachment (form ESR/2015/1791) for an application for an environmental authority accompanies this development application, and details are provided in the table below
- No

Note: Application for an environmental authority can be found by searching "ESR/2015/1791" as a search term at www.qld.gov.au. An ERA requires an environmental authority to operate. See www.business.qld.gov.au for further information.

Proposed ERA number:		Proposed ERA threshold:	
Proposed ERA name:			

- Multiple ERAs are applicable to this development application and the details have been attached in a schedule to this development application.

Hazardous chemical facilities

23.2) Is this development application for a **hazardous chemical facility**?

- Yes – *Form 536: Notification of a facility exceeding 10% of schedule 15 threshold* is attached to this development application
- No

Note: See www.business.qld.gov.au for further information about hazardous chemical notifications.

Clearing native vegetation

23.3) Does this development application involve **clearing native vegetation** that requires written confirmation that the chief executive of the *Vegetation Management Act 1999* is satisfied the clearing is for a relevant purpose under section 22A of the *Vegetation Management Act 1999*?

- Yes – this development application includes written confirmation from the chief executive of the *Vegetation Management Act 1999* (s22A determination)
- No

Note: 1. Where a development application for operational work or material change of use requires a s22A determination and this is not included, the development application is prohibited development.
2. See <https://www.qld.gov.au/environment/land/vegetation/applying> for further information on how to obtain a s22A determination.

Environmental offsets

23.4) Is this development application taken to be a prescribed activity that may have a significant residual impact on a **prescribed environmental matter** under the *Environmental Offsets Act 2014*?

- Yes – I acknowledge that an environmental offset must be provided for any prescribed activity assessed as having a significant residual impact on a prescribed environmental matter
- No

Note: The environmental offset section of the Queensland Government's website can be accessed at www.qld.gov.au for further information on environmental offsets.

Koala habitat in SEQ Region

23.5) Does this development application involve a material change of use, reconfiguring a lot or operational work which is assessable development under Schedule 10, Part 10 of the Planning Regulation 2017?

- Yes – the development application involves premises in the koala habitat area in the koala priority area
- Yes – the development application involves premises in the koala habitat area outside the koala priority area
- No

Note: If a koala habitat area determination has been obtained for this premises and is current over the land, it should be provided as part of this development application. See koala habitat area guidance materials at www.desi.qld.gov.au for further information.



Water resources

23.6) Does this development application involve **taking or interfering with underground water through an artesian or subartesian bore, taking or interfering with water in a watercourse, lake or spring, or taking overland flow water under the *Water Act 2000***?

Yes – the relevant template is completed and attached to this development application and I acknowledge that a relevant authorisation or licence under the *Water Act 2000* may be required prior to commencing development

No

Note: Contact the Department of Resources at www.resources.qld.gov.au for further information.

DA templates are available from planning.statedevelopment.qld.gov.au. If the development application involves:

- Taking or interfering with underground water through an artesian or subartesian bore: complete DA Form 1 Template 1
- Taking or interfering with water in a watercourse, lake or spring: complete DA Form 1 Template 2
- Taking overland flow water: complete DA Form 1 Template 3.

Waterway barrier works

23.7) Does this application involve **waterway barrier works**?

Yes – the relevant template is completed and attached to this development application

No

DA templates are available from planning.statedevelopment.qld.gov.au. For a development application involving waterway barrier works, complete DA Form 1 Template 4.

Marine activities

23.8) Does this development application involve **aquaculture, works within a declared fish habitat area or removal, disturbance or destruction of marine plants**?

Yes – an associated resource allocation authority is attached to this development application, if required under the *Fisheries Act 1994*

No

Note: See guidance materials at www.daf.qld.gov.au for further information.

Quarry materials from a watercourse or lake

23.9) Does this development application involve the **removal of quarry materials from a watercourse or lake under the *Water Act 2000***?

Yes – I acknowledge that a quarry material allocation notice must be obtained prior to commencing development

No

Note: Contact the Department of Resources at www.resources.qld.gov.au and www.business.qld.gov.au for further information.

Quarry materials from land under tidal waters

23.10) Does this development application involve the **removal of quarry materials from land under tidal water under the *Coastal Protection and Management Act 1995***?

Yes – I acknowledge that a quarry material allocation notice must be obtained prior to commencing development

No

Note: Contact the Department of Environment, Science and Innovation at www.desi.qld.gov.au for further information.

Referable dams

23.11) Does this development application involve a **referable dam** required to be failure impact assessed under section 343 of the *Water Supply (Safety and Reliability) Act 2008* (the *Water Supply Act*)?

Yes – the 'Notice Accepting a Failure Impact Assessment' from the chief executive administering the *Water Supply Act* is attached to this development application

No

Note: See guidance materials at www.resources.qld.gov.au for further information.



Tidal work or development within a coastal management district

23.12) Does this development application involve **tidal work or development in a coastal management district**?

- Yes – the following is included with this development application:
- Evidence the proposal meets the code for assessable development that is prescribed tidal work (*only required if application involves prescribed tidal work*)
 - A certificate of title

No

Note: See guidance materials at www.desi.qld.gov.au for further information.

Queensland and local heritage places

23.13) Does this development application propose development on or adjoining a place entered in the **Queensland heritage register** or on a place entered in a local government's **Local Heritage Register**?

Yes – details of the heritage place are provided in the table below

No

Note: See guidance materials at www.desi.qld.gov.au for information requirements regarding development of Queensland heritage places. For a heritage place that has cultural heritage significance as a local heritage place and a Queensland heritage place, provisions are in place under the Planning Act 2016 that limit a local categorising instrument from including an assessment benchmark about the effect or impact of, development on the stated cultural heritage significance of that place. See guidance materials at www.planning.statedevelopment.qld.gov.au for information regarding assessment of Queensland heritage places.

Name of the heritage place:

Place ID:

Decision under section 62 of the Transport Infrastructure Act 1994

23.14) Does this development application involve new or changed access to a state-controlled road?

Yes – this application will be taken to be an application for a decision under section 62 of the *Transport Infrastructure Act 1994* (subject to the conditions in section 75 of the *Transport Infrastructure Act 1994* being satisfied)

No

Walkable neighbourhoods assessment benchmarks under Schedule 12A of the Planning Regulation

23.15) Does this development application involve reconfiguring a lot into 2 or more lots in certain residential zones (except rural residential zones), where at least one road is created or extended?

Yes – Schedule 12A is applicable to the development application and the assessment benchmarks contained in schedule 12A have been considered

No

Note: See guidance materials at www.planning.statedevelopment.qld.gov.au for further information.

PART 8 – CHECKLIST AND APPLICANT DECLARATION

24) Development application checklist

I have identified the assessment manager in question 15 and all relevant referral requirement(s) in question 17

Yes

Note: See the *Planning Regulation 2017* for referral requirements

If building work is associated with the proposed development, Parts 4 to 6 of [DA Form 2 – Building work details](#) have been completed and attached to this development application

Yes

Not applicable

Supporting information addressing any applicable assessment benchmarks is with the development application

Note: This is a mandatory requirement and includes any relevant templates under question 23, a planning report and any technical reports required by the relevant categorising instruments (e.g. local government planning schemes, State Planning Policy, State Development Assessment Provisions). For further information, see [DA Forms Guide: Planning Report Template](#).

Yes

Relevant plans of the development are attached to this development application

Note: Relevant plans are required to be submitted for all aspects of this development application. For further information, see [DA Forms Guide: Relevant plans](#).

Yes

The portable long service leave levy for QLeave has been paid, or will be paid before a development permit is issued (see 21)

Yes

Not applicable



25) Applicant declaration

- By making this development application, I declare that all information in this development application is true and correct
- Where an email address is provided in Part 1 of this form, I consent to receive future electronic communications from the assessment manager and any referral agency for the development application where written information is required or permitted pursuant to sections 11 and 12 of the *Electronic Transactions Act 2001*

Note: It is unlawful to intentionally provide false or misleading information.

Privacy – Personal information collected in this form will be used by the assessment manager and/or chosen assessment manager, any relevant referral agency and/or building certifier (including any professional advisers which may be engaged by those entities) while processing, assessing and deciding the development application. All information relating to this development application may be available for inspection and purchase, and/or published on the assessment manager’s and/or referral agency’s website.

Personal information will not be disclosed for a purpose unrelated to the *Planning Act 2016*, Planning Regulation 2017 and the DA Rules except where:

- such disclosure is in accordance with the provisions about public access to documents contained in the *Planning Act 2016* and the Planning Regulation 2017, and the access rules made under the *Planning Act 2016* and Planning Regulation 2017; or
- required by other legislation (including the *Right to Information Act 2009*); or
- otherwise required by law.

This information may be stored in relevant databases. The information collected will be retained as required by the *Public Records Act 2002*.

PART 9 – FOR COMPLETION OF THE ASSESSMENT MANAGER – FOR OFFICE USE ONLY

Date received: Reference number(s):

Notification of engagement of alternative assessment manager

Prescribed assessment manager	
Name of chosen assessment manager	
Date chosen assessment manager engaged	
Contact number of chosen assessment manager	
Relevant licence number(s) of chosen assessment manager	

QLeave notification and payment

Note: For completion by assessment manager if applicable

Description of the work	Shed Extension		
QLeave project number			
Amount paid (\$)	\$ 0.00	Date paid (dd/mm/yy)	
Date receipted form sighted by assessment manager			
Name of officer who sighted the form	Scott Wheeler		

DA Form 2 – Building work details

Approved form (version 1.2 effective 7 February 2020) made under Section 282 of the Planning Act 2016.

This form **must** be used to make a development application **involving building work**.

For a development application involving **building work only**, use this form (DA Form 2) only. The DA Forms Guide provides advice about how to complete this form.

For a development application involving **building work associated and any other type of assessable development** (i.e. material change of use, operational work or reconfiguring a lot), use *DA Form 1 – Development application details* and parts 4 to 6 of this form (DA Form 2).

Unless stated otherwise, all parts of this form **must** be completed in full and all required supporting information **must** accompany the development application.

One or more additional pages may be attached as a schedule to this development application if there is insufficient space on the form to include all the necessary information.

This form and any other form relevant to the development application must be used to make a development application relating to strategic port land and Brisbane core port land under the *Transport Infrastructure Act 1994*, and airport land under the *Airport Assets (Restructuring and Disposal) Act 2008*. For the purpose of assessing a development application relating to strategic port land and Brisbane core port land, any reference to a planning scheme is taken to mean a land use plan for the strategic port land, Brisbane port land use plan for Brisbane core port land, or a land use plan for airport land.

Note: All terms used in this form have the meaning given under the Planning Act 2016, the Planning Regulation 2017, or the Development Assessment Rules (DA Rules).

PART 1 – APPLICANT DETAILS

1) Applicant details	
Applicant name(s) (individual or company full name)	Greg Santarossa C/- Rapid Building Approvals
Contact name (only applicable for companies)	Scott Wheeler
Postal address (PO Box or street address)	
Suburb	
State	
Postcode	
Country	
Contact number	
Email address (non-mandatory)	gregsantarossa@gmail.com
Mobile number (non-mandatory)	
Fax number (non-mandatory)	
Applicant's reference number(s) (if applicable)	2060/26

PART 2 – LOCATION DETAILS

2) Location of the premises (complete 2.1 and 2.2 if applicable)

Note: Provide details below and attach a site plan for any or all premises part of the development application. For further information, see [DA Forms Guide: Relevant plans](#).

2.1) Street address and lot on plan

- Street address **AND** lot on plan (all lots must be listed), **or**
 Street address **AND** lot on plan for an adjoining or adjacent property of the premises (appropriate for development in water but adjoining or adjacent to land e.g. jetty, pontoon. All lots must be listed).

Unit No.	Street No.	Street Name and Type	Suburb
	256	Bamboo Creek Road	Bamboo



Queensland
Government

Postcode	Lot No.	Plan Type and Number (e.g. RP, SP)	Local Government Area(s)
4873	3	RP865065	Douglas Shire Council

2.2) Additional premises

- Additional premises are relevant to this development application and the details of these premises have been attached in a schedule to this development application
- Not required

3) Are there any existing easements over the premises?

Note: Easement uses vary throughout Queensland and are to be identified correctly and accurately. For further information on easements and how they may affect the proposed development, see the [DA Forms Guide](#)

- Yes – All easement locations, types and dimensions are included in plans submitted with this development application
- No

PART 3 – FURTHER DETAILS

4) Is the application only for building work assessable against the building assessment provisions?

- Yes – proceed to 8)
- No

5) Identify the assessment manager(s) who will be assessing this development application

Douglas Shire Council

6) Has the local government agreed to apply a superseded planning scheme for this development application?

- Yes – a copy of the decision notice is attached to this development application
- The local government is taken to have agreed to the superseded planning scheme request – relevant documents attached
- No

7) Information request under Part 3 of the DA Rules

- I agree to receive an information request if determined necessary for this development application
- I do not agree to accept an information request for this development application

Note: By not agreeing to accept an information request I, the applicant, acknowledge:

- that this development application will be assessed and decided based on the information provided when making this development application and the assessment manager and any referral agencies relevant to the development application are not obligated under the DA Rules to accept any additional information provided by the applicant for the development application unless agreed to by the relevant parties.
- Part 3 of the DA Rules will still apply if the application is an application listed under section 11.3 of the DA Rules.

Further advice about information requests is contained in the [DA Forms Guide](#).

8) Are there any associated development applications or current approvals?

- Yes – provide details below or include details in a schedule to this development application
- No

List of approval/development application	Reference	Date	Assessment manager
<input type="checkbox"/> Approval			
<input type="checkbox"/> Development application			
<input type="checkbox"/> Approval			
<input type="checkbox"/> Development application			

9) Has the portable long service leave levy been paid?

- Yes – a copy of the receipted QLeave form is attached to this development application

<input type="checkbox"/> No – I, the applicant will provide evidence that the portable long service leave levy has been paid before the assessment manager decides the development application. I acknowledge that the assessment manager may give a development approval only if I provide evidence that the portable long service leave levy has been paid <input checked="" type="checkbox"/> Not applicable (e.g. building and construction work is less than \$150,000 excluding GST)		
Amount paid	Date paid (dd/mm/yy)	QLeave levy number (A, B or E)
\$ 0.00		
10) Is this development application in response to a show cause notice or required as a result of an enforcement notice?		
<input type="checkbox"/> Yes – show cause or enforcement notice is attached <input checked="" type="checkbox"/> No		

11) Identify any of the following further legislative requirements that apply to any aspect of this development application		
<input type="checkbox"/> The proposed development is on a place entered in the Queensland Heritage Register or in a local government's Local Heritage Register . See the guidance provided at www.des.qld.gov.au about the requirements in relation to the development of a Queensland heritage place		
Name of the heritage place:		Place ID:

PART 4 – REFERRAL DETAILS

12) Does this development application include any building work aspects that have any referral requirements?	
<input type="checkbox"/> Yes – the <i>Referral checklist for building work</i> is attached to this development application <input checked="" type="checkbox"/> No – proceed to Part 5	

13) Has any referral agency provided a referral response for this development application?		
<input type="checkbox"/> Yes – referral response(s) received and listed below are attached to this development application <input type="checkbox"/> No		
Referral requirement	Referral agency	Date referral response
Identify and describe any changes made to the proposed development application that was the subject of the referral response and this development application, or include details in a schedule to this development application (if applicable)		

PART 5 – BUILDING WORK DETAILS

14) Owner's details	
<input type="checkbox"/> Tick if the applicant is also the owner and proceed to 15). Otherwise, provide the following information.	
Name(s) (individual or company full name)	
Contact name (applicable for companies)	Russell Duncan
Postal address (P.O. Box or street address)	PO Box 640
Suburb	Mossman
State	QLD
Postcode	4873
Country	
Contact number	
Email address (non-mandatory)	lissnuss@bigpond.com

Mobile number <i>(non-mandatory)</i>	0427 529 482		
Fax number <i>(non-mandatory)</i>			
15) Builder's details			
<input type="checkbox"/> Tick if a builder has not yet been engaged to undertake the work and proceed to 16). Otherwise provide the following information.			
Name(s) <i>(individual or company full name)</i>			
Contact name <i>(applicable for companies)</i>	Greg Santarossa		
QBCC licence or owner – builder number			
Postal address <i>(P.O. Box or street address)</i>			
Suburb			
State			
Postcode			
Contact number			
Email address <i>(non-mandatory)</i>	gregsantarossa@gmail.com		
Mobile number <i>(non-mandatory)</i>			
Fax number <i>(non-mandatory)</i>			
16) Provide details about the proposed building work			
What type of approval is being sought?			
<input checked="" type="checkbox"/> Development permit			
<input type="checkbox"/> Preliminary approval			
b) What is the level of assessment?			
<input checked="" type="checkbox"/> Code assessment			
<input type="checkbox"/> Impact assessment <i>(requires public notification)</i>			
c) Nature of the proposed building work (tick all applicable boxes)			
<input checked="" type="checkbox"/> New building or structure		<input type="checkbox"/> Repairs, alterations or additions	
<input type="checkbox"/> Change of building classification <i>(involving building work)</i>		<input type="checkbox"/> Construction of Swimming pool or spa	
<input type="checkbox"/> Extension		<input type="checkbox"/> Re-erection	
<input type="checkbox"/> Demolition		<input type="checkbox"/> Relocation or removal	
<input type="checkbox"/> Construction of swimming pool or spa barrier		<input type="checkbox"/> Other	
d) Provide a description of the work below or in an attached schedule.			
Shed Extension			
e) Proposed construction materials			
External walls	<input type="checkbox"/> Double Brick	<input checked="" type="checkbox"/> Steel	<input type="checkbox"/> Curtain glass
	<input type="checkbox"/> Brick Veener	<input type="checkbox"/> Timber	<input type="checkbox"/> Aluminium
	<input type="checkbox"/> Stone/concrete	<input type="checkbox"/> Fibre cement	<input type="checkbox"/> Other
Frame	<input type="checkbox"/> Timber	<input checked="" type="checkbox"/> Steel	<input type="checkbox"/> Aluminium
	<input type="checkbox"/> Other		
Floor	<input checked="" type="checkbox"/> Concrete/Stone/Slate	<input type="checkbox"/> Timber	<input type="checkbox"/> Other
Roof covering	<input type="checkbox"/> Concrete/Stone/Slate	<input type="checkbox"/> Tiles	<input type="checkbox"/> Fibre cement
	<input type="checkbox"/> Aluminium	<input checked="" type="checkbox"/> Steel	<input type="checkbox"/> Other
f) Existing building use/classification? <i>(if applicable)</i>			
Dwelling			
g) New building use/classification? <i>(if applicable)</i>			

10a
h) Relevant plans <i>Note: Relevant plans are required to be submitted for all aspects of this development application. For further information, see DA Forms Guide: Relevant plans.</i>
<input checked="" type="checkbox"/> Relevant plans of the proposed works are attached to the development application
17) What is the monetary value of the proposed building work?
\$ 0.00

18) Has Queensland Home Warranty Scheme Insurance been paid?		
<input type="checkbox"/> Yes – provide details below		
<input checked="" type="checkbox"/> No		
Amount paid	Date paid (dd/mm/yy)	Reference number

PART 6 – CHECKLIST AND APPLICANT DECLARATION

19) Development application checklist	
The relevant parts of <i>Form 2 – Building work details</i> have been completed	<input checked="" type="checkbox"/> Yes
This development application includes a material change of use, reconfiguring a lot or operational work and is accompanied by a completed <i>Form 1 – Development application details</i>	<input checked="" type="checkbox"/> Yes <input type="checkbox"/> Not applicable
Relevant plans of the development are attached to this development application <i>Note: Relevant plans are required to be submitted for all aspects of this development application. For further information, see DA Forms Guide: Relevant plans.</i>	<input checked="" type="checkbox"/> Yes
The portable long service leave levy for QLeave has been paid, or will be paid before a development permit is issued (<i>see 9</i>)	<input type="checkbox"/> Yes <input checked="" type="checkbox"/> Not applicable

20) Applicant declaration
<input checked="" type="checkbox"/> By making this development application, I declare that all information in this development application is true and correct
<input checked="" type="checkbox"/> Where an email address is provided in Part 1 of this form, I consent to receive future electronic communications from the assessment manager and any referral agency for the development application where written information is required or permitted pursuant to sections 11 and 12 of the <i>Electronic Transactions Act 2001</i> <i>Note: It is unlawful to intentionally provide false or misleading information.</i>
Privacy – Personal information collected in this form will be used by the assessment manager and/or chosen assessment manager, any referral agency and/or building certifier (including any professional advisers which may be engaged by those entities) while processing, assessing and deciding the development application. All information relating to this development application may be available for inspection and purchase, and/or published on the assessment manager's and/or referral agency's website. Personal information will not be disclosed for a purpose unrelated to the <i>Planning Act 2016</i> , Planning Regulation 2017 and the DA Rules except where: <ul style="list-style-type: none"> • such disclosure is in accordance with the provisions about public access to documents contained in the <i>Planning Act 2016</i> and the Planning Regulation 2017, and the access rules made under the <i>Planning Act 2016</i> and Planning Regulation 2017; or • required by other legislation (including the <i>Right to Information Act 2009</i>); or • otherwise required by law. This information may be stored in relevant databases. The information collected will be retained as required by the <i>Public Records Act 2002</i> .

PART 7 – FOR COMPLETION BY THE ASSESSMENT MANAGER – FOR OFFICE USE ONLY

Date received: Reference numbers:

For completion by the building certifier

Classification(s) of approved building work

10a		
Name	QBCC Certification Licence number	QBCC Insurance receipt number
Scott Wheeler	A15149770	

Notification of engagement of alternative assessment manager

Prescribed assessment manager	
Name of chosen assessment manager	
Date chosen assessment manager engaged	
Contact number of chosen assessment manager	
Relevant licence number(s) of chosen assessment manager	

Additional information required by the local government

Confirm proposed construction materials:

External walls	<input type="checkbox"/> Double brick	<input checked="" type="checkbox"/> Steel	<input type="checkbox"/> Curtain glass
	<input type="checkbox"/> Brick veneer	<input type="checkbox"/> Timber	<input type="checkbox"/> Aluminium
	<input type="checkbox"/> Stone/concrete	<input type="checkbox"/> Fibre cement	<input type="checkbox"/> Other
Frame	<input type="checkbox"/> Timber	<input checked="" type="checkbox"/> Steel	<input type="checkbox"/> Aluminium
	<input type="checkbox"/> Other		
Floor	<input checked="" type="checkbox"/> Concrete/Stone/Slate	<input type="checkbox"/> Timber	<input type="checkbox"/> Other
Roof covering	<input type="checkbox"/> Concrete/Stone/Slate	<input type="checkbox"/> Tiles	<input type="checkbox"/> Fibre cement
	<input type="checkbox"/> Aluminium	<input checked="" type="checkbox"/> Steel	<input type="checkbox"/> Other

QLeave notification and payment

Note: For completion by assessment manager if applicable

Description of the work	Shed Extension		
QLeave project number			
Amount paid (\$)	0.0000	Date paid (dd/mm/yy)	
Date receipted form sighted by assessment manager			
Name of officer who sighted the form	Scott Wheeler		

Additional building details required for the Australian Bureau of Statistics

Existing building use/classification? (if applicable)	Dwelling		
New building use/classification?	10a		
Site area (m ²)	4050m ²	Floor area (m ²)	47.25m ²

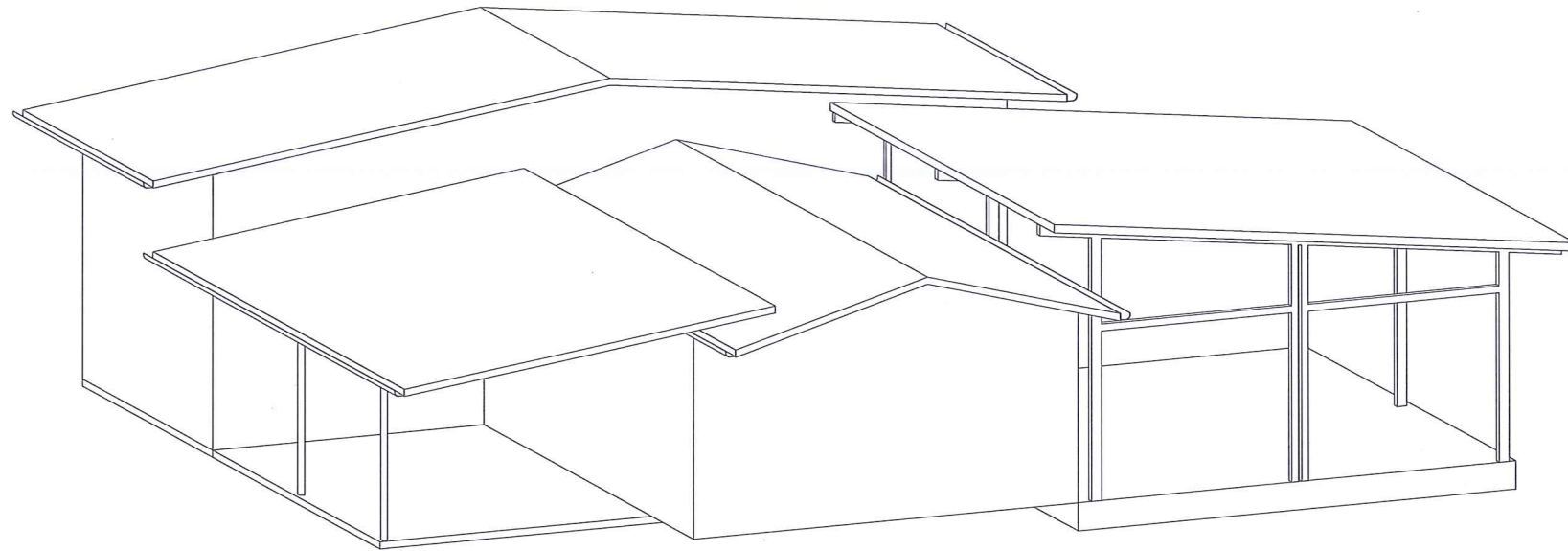

1 3D from SW

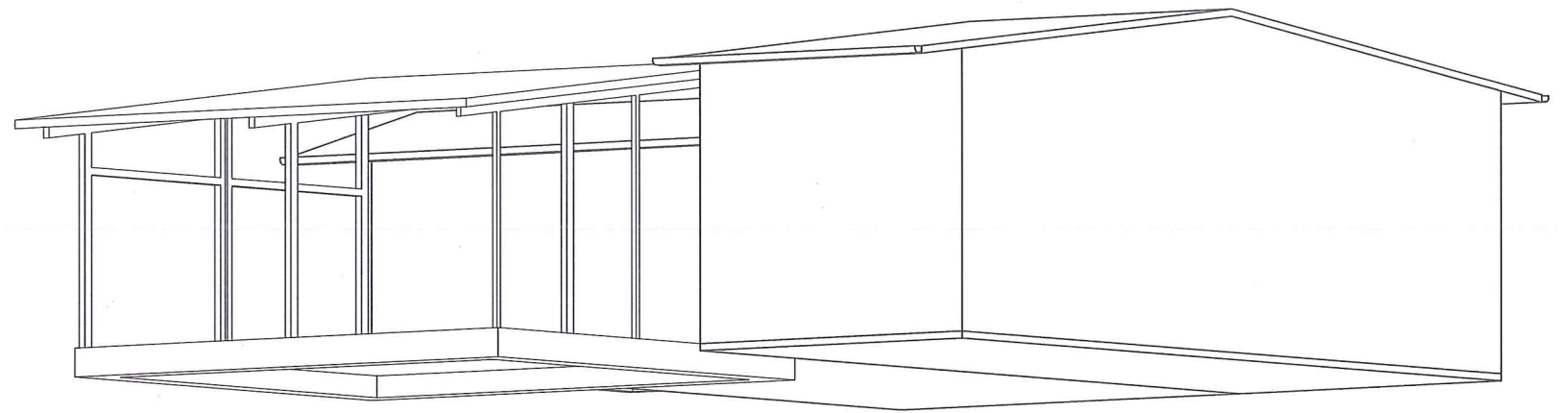

2 3D from NE

STRUCTURAL DETAILS
ADEQUATE AS CERTIFIED

[Signature]

RODGERS CONSULTING ENGINEERS
H P Rodgers RPEQ 7859

JOB NO: 260131	DATE: 17/04/2026
-------------------	---------------------

RODGERS Consulting Engineers Ph. 40 519 466	These drawings are copyright and must not be copied or retained. Do not scale from drawings. The contractor & sub-contractors are to verify all dimensions before commencing work and bring to the attention of the designer any discrepancies they may find.	R & M Duncan 256 Bamboo Ck. Rd. Bamboo Proposed Shed Extension.	LAWSON DESIGN PH. 40 532 058 M. 0412 592 900 P.O. Box 349 EDGE HILL 4870 Building Designers Assoc. Qld. QBSA no. 24590	Site Classification TBC Design Wind Speed C2	Date 17/4/26 Amendments	JOB No. 2502 DWG. No. 01
--	--	--	--	---	--------------------------------------	---

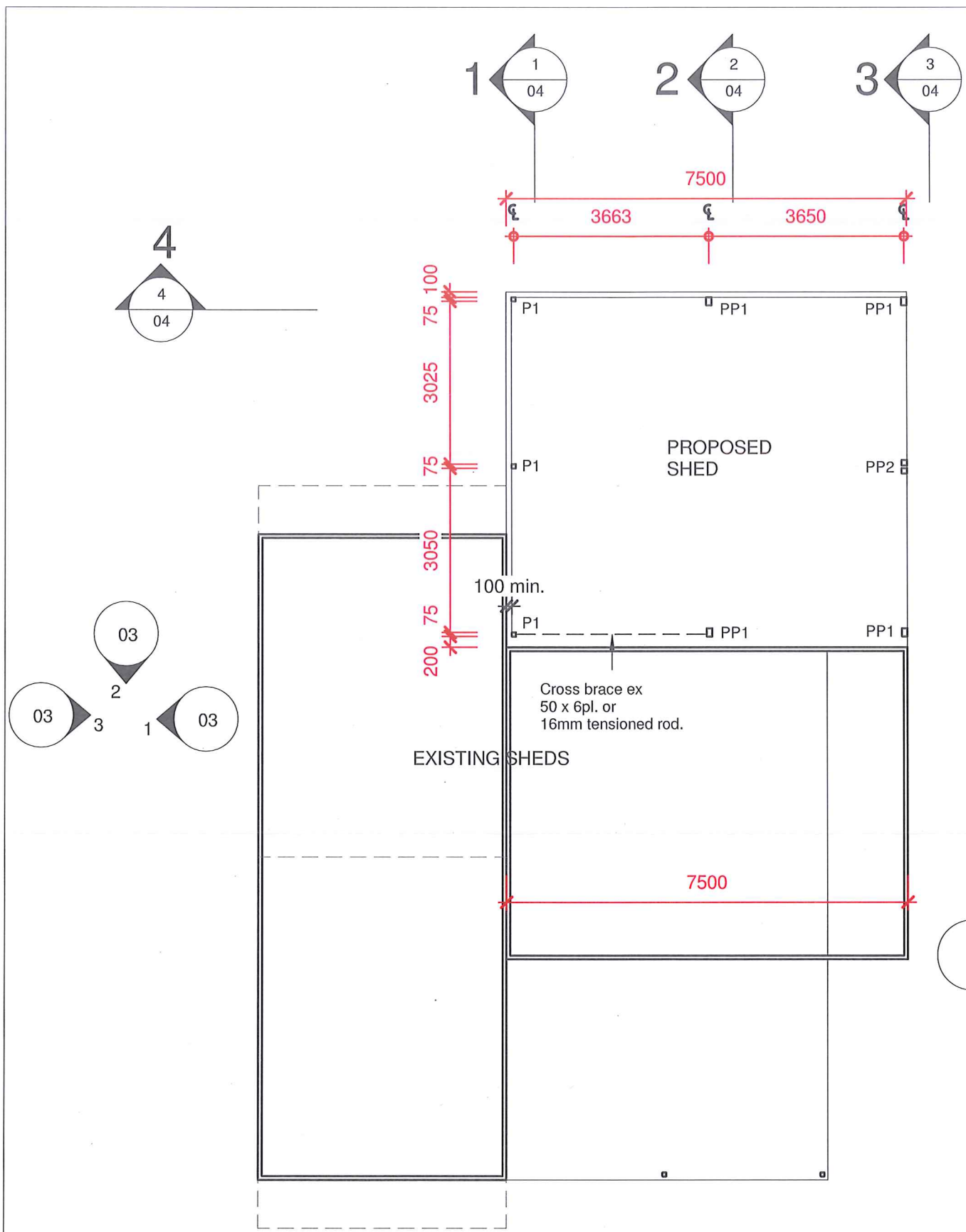

1 Proposed Floor Plan
1 : 100

- Roof Legend**
1 : 50
- P1 75x4.0 shs Post
 - PP1 150x100x4.0 Portal Post
 - PP2 2x100x4.0 Portal Posts
See Section 3
 - RB1 125x75x4.0 rhs Roof Beam
 - PB1 150x100x4.0 rhs Portal Beam

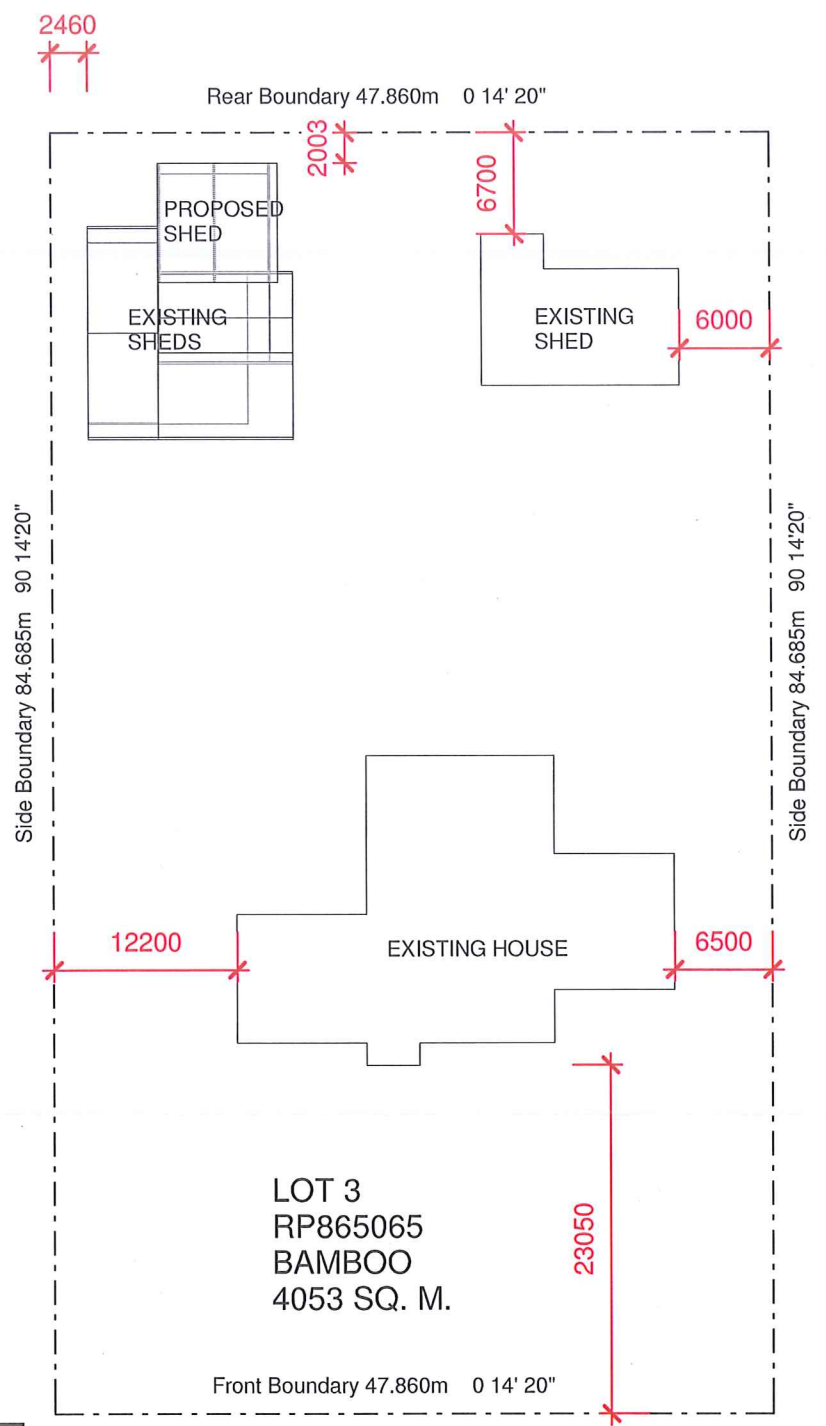

2 Site Plan
1 : 500

**STRUCTURAL DETAILS
ADEQUATE AS CERTIFIED**

[Signature]

RODGERS CONSULTING ENGINEERS
H P Rodgers RPEQ 7859

JOB NO: 260131	DATE: 17/04/2026
--------------------------	----------------------------

RODGERS Consulting Engineers Ph. 40 519 466	These drawings are copyright and must not be copied or retained. Do not scale from drawings. The contractor & sub-contractors are to verify all dimensions before commencing work and bring to the attention of the designer any discrepancies they may find.	R & M Duncan 256 Bamboo Ck. Rd. Bamboo Proposed Shed Extension.	LAWSON DESIGN PH. 40 532 058 M. 0412 592 900 P.O. Box 349 EDGE HILL 4870 Building Designers Assoc. Qld. QBSA no. 24590	Site Classification TBC Design Wind Speed C2	Date 17/4/26 Amendments	JOB No. 2502 DWG. No. 02
--	---	--	--	---	--------------------------------------	---

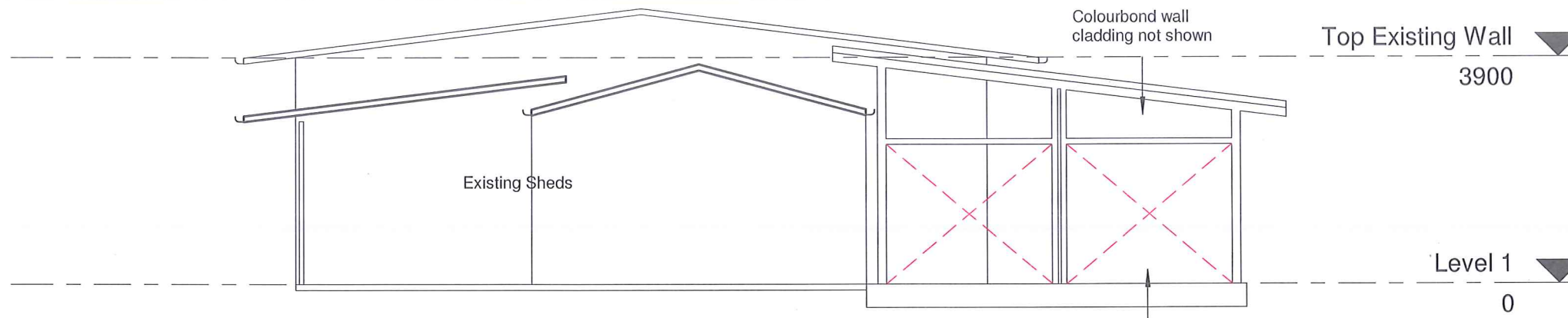

1 Elevation Right
1 : 100

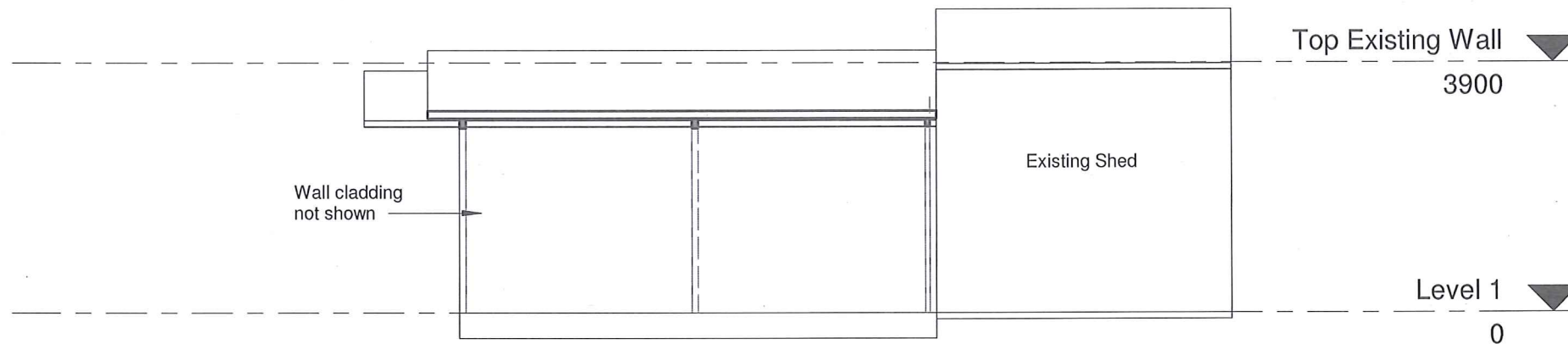

2 Elevation Rear
1 : 100

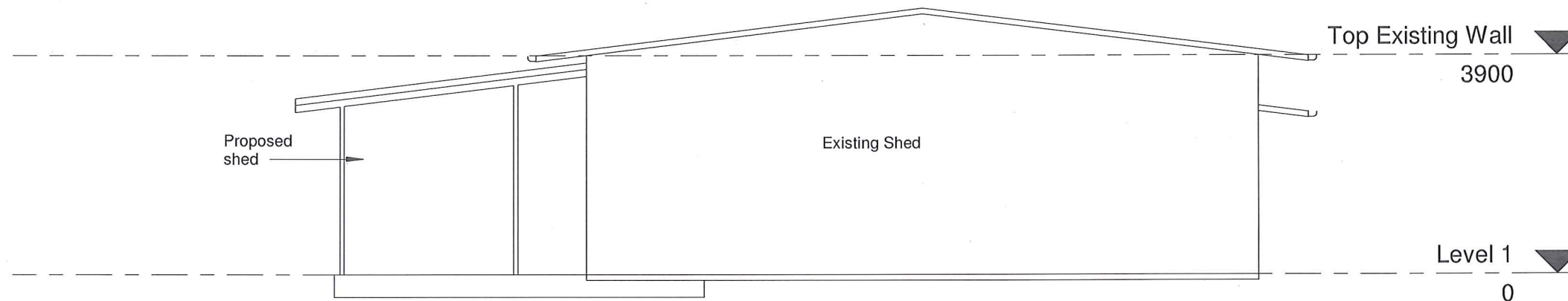

3 Elevation Left
1 : 100

STRUCTURAL DETAILS
ADEQUATE AS CERTIFIED

[Signature]

RODGERS CONSULTING ENGINEERS
H P Rodgers RPEQ 7859

JOB NO: 260131 DATE: 17/04/2026

RODGERS
Consulting Engineers
Ph. 40 519 466

These drawings are copyright and must not be copied or retained.
Do not scale from drawings. The contractor & sub-contractors are to verify all dimensions before commencing work and bring to the attention of the designer any discrepancies they may find.

R & M Duncan
256 Bamboo Ck. Rd. Bamboo
Proposed Shed Extension.

LAWSON DESIGN
PH. 40 532 058 M. 0412 592 900
P.O. Box 349 EDGE HILL 4870
Building Designers Assoc. Qld. QBSA no. 24590

Site Classification TBC	Date 17/4/26	JOB No. 2502
Design Wind Speed C2	Amendments	DWG. No. 03

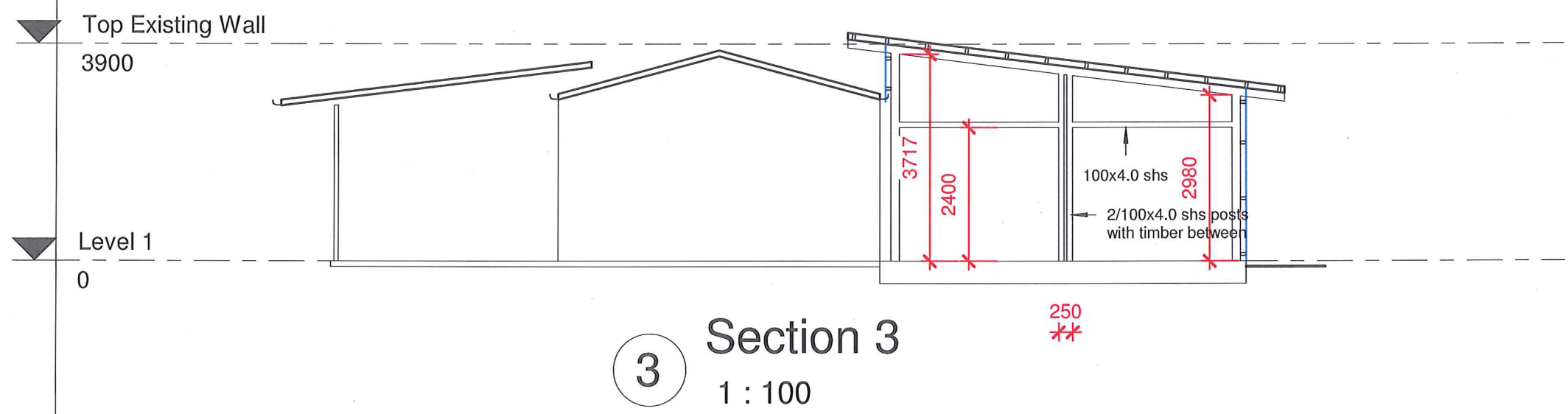
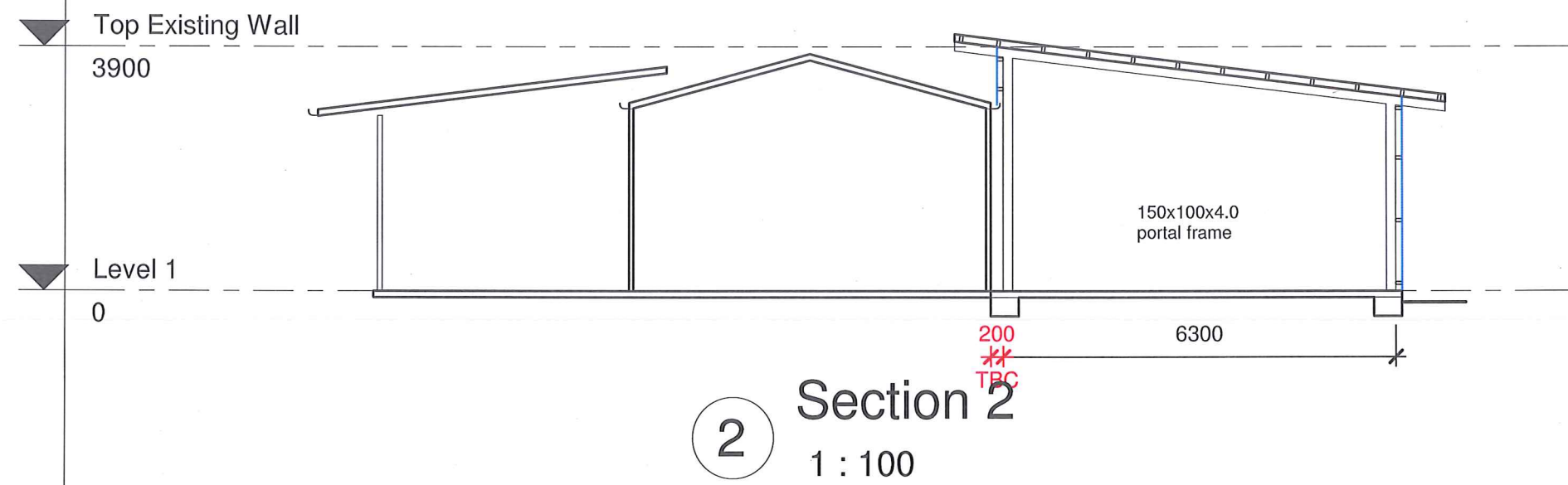
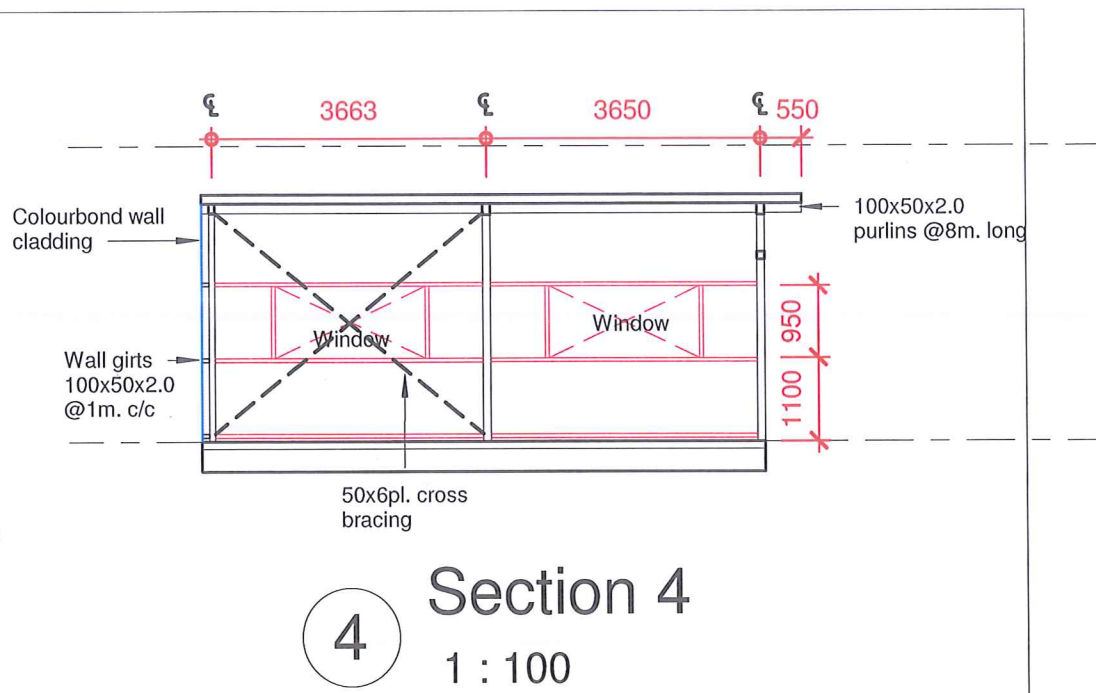
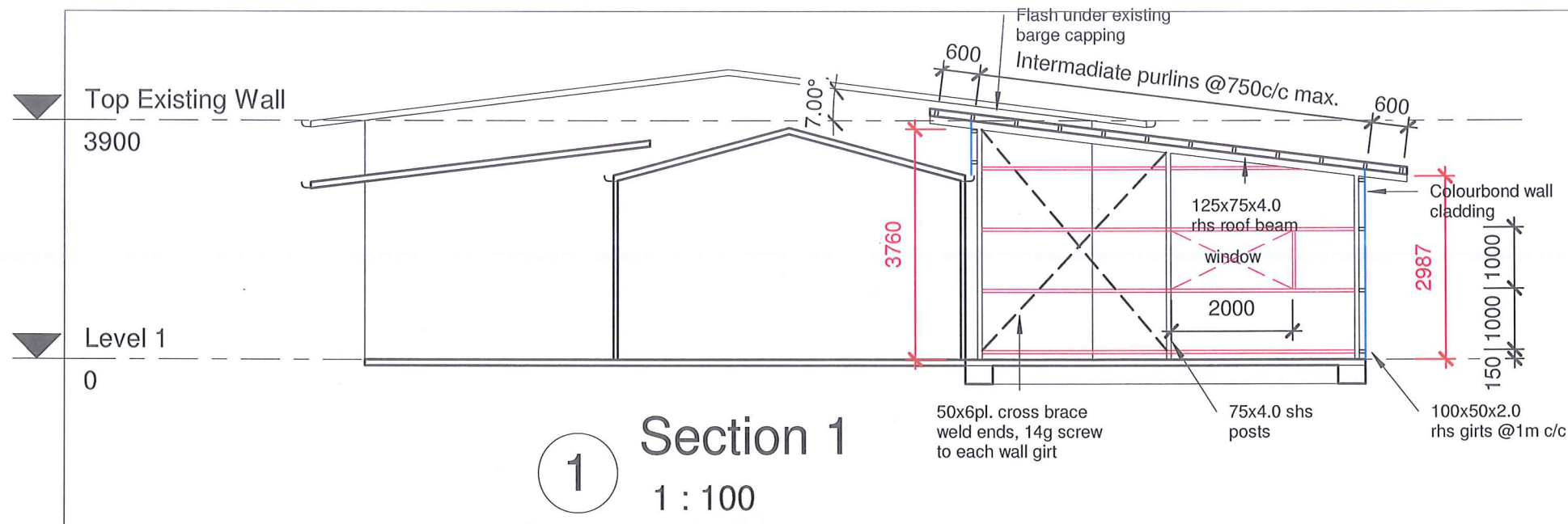

STRUCTURAL DETAILS
ADEQUATE AS CERTIFIED

[Signature]

RODGERS CONSULTING ENGINEERS
H P Rodgers RPEQ 7859

JOB NO: 260131	DATE: 17/04/2026
-------------------	---------------------

RODGERS
Consulting Engineers
Ph. 40 519 466

These drawings are copyright and must not be copied or retained. Do not scale from drawings. The contractor & sub-contractors are to verify all dimensions before commencing work and bring to the attention of the designer any discrepancies they may find.

R & M Duncan
256 Bamboo Ck. Rd. Bamboo
Proposed Shed Extension.

LAWSON DESIGN
PH. 40 532 058 M. 0412 592 900
P.O. Box 349 EDGE HILL 4870
Building Designers Assoc. Qld. QBSA no. 24590

Site Classification
TBC
Design Wind Speed
C2

Date
17/4/26
Amendments

JOB No. **2502**
DWG. No. **04**

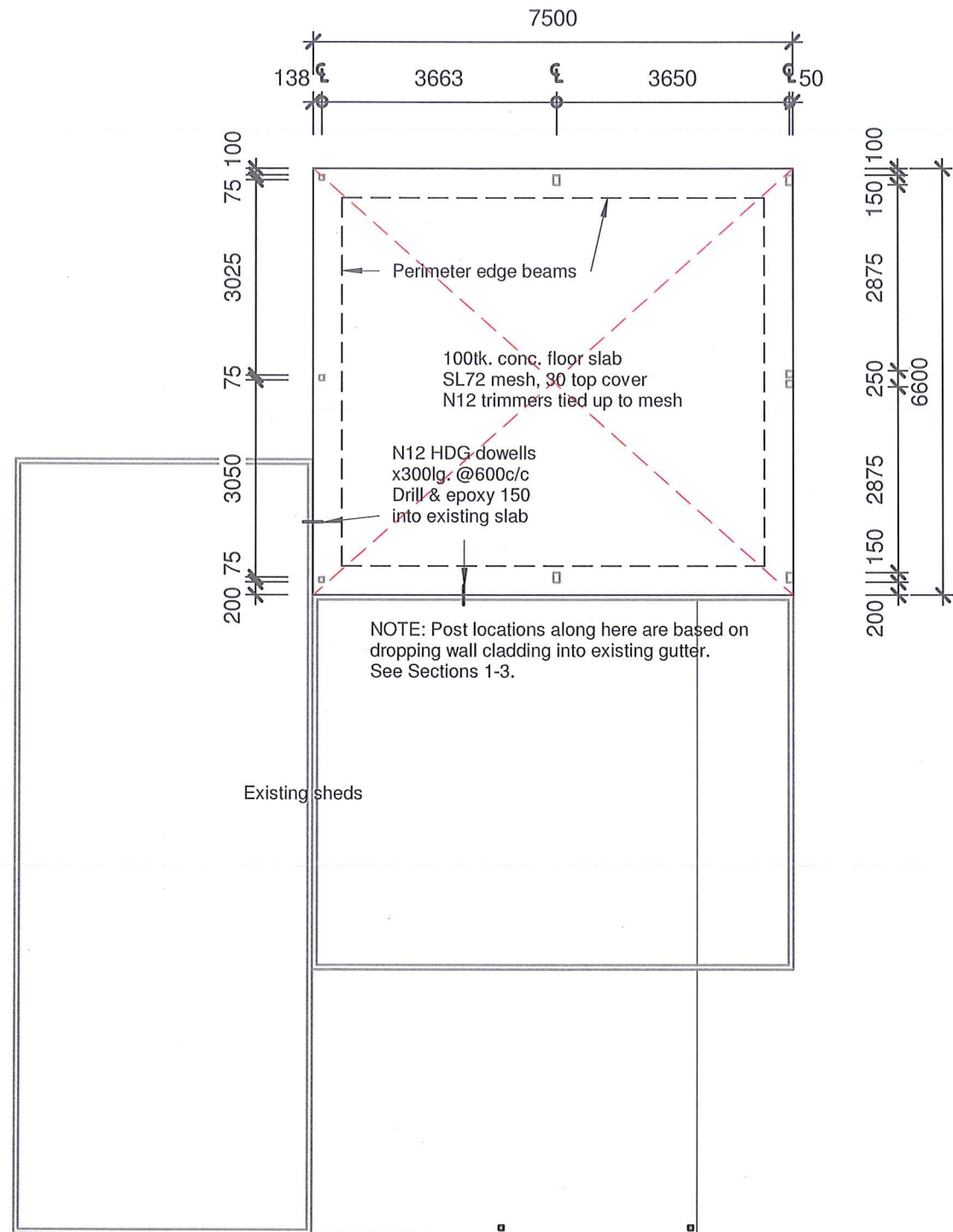

1 Foundation Plan
1 : 100

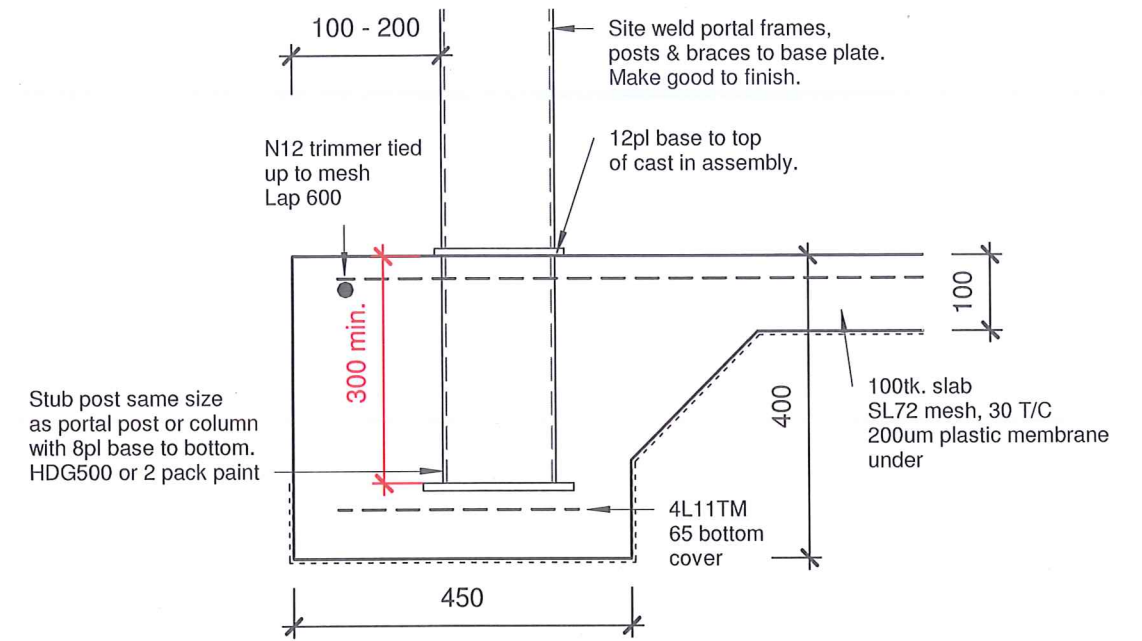

Base Plate Option

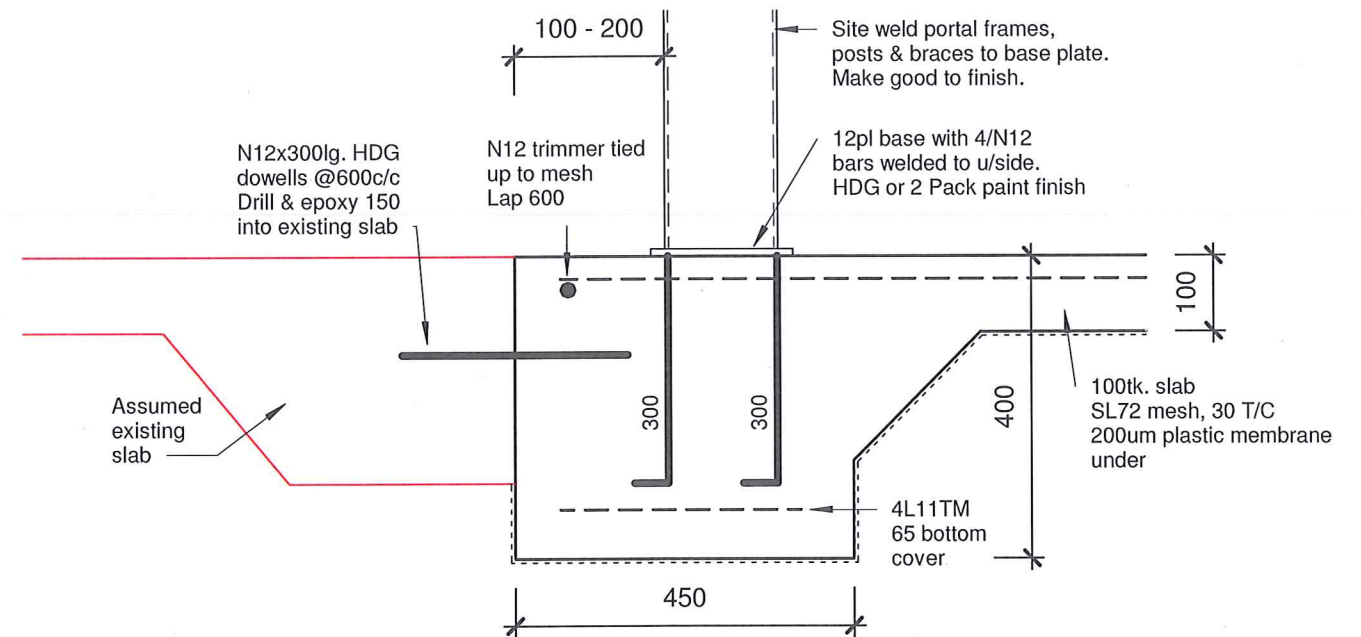

2 Edge beam
1 : 10

**STRUCTURAL DETAILS
ADEQUATE AS CERTIFIED**

[Signature]

**RODGERS CONSULTING ENGINEERS
H P Rodgers RPEQ 7859**

JOB NO: 260131	DATE: 17/04/2026
--------------------------	----------------------------

RODGERS Consulting Engineers Ph. 40 519 466	These drawings are copyright and must not be copied or retained. Do not scale from drawings. The contractor & sub-contractors are to verify all dimensions before commencing work and bring to the attention of the designer any discrepancies they may find.	R & M Duncan 256 Bamboo Ck. Rd. Bamboo Proposed Shed Extension.	LAWSON DESIGN PH. 40 532 058 M. 0412 592 900 P.O. Box 349 EDGE HILL 4870 Building Designers Assoc. Qld. QBSA no. 24590	Site Classification TBC Design Wind Speed C2	Date 17/4/26 Amendments	JOB No. 2502 DWG. No. 05
--	---	--	--	---	--------------------------------------	---

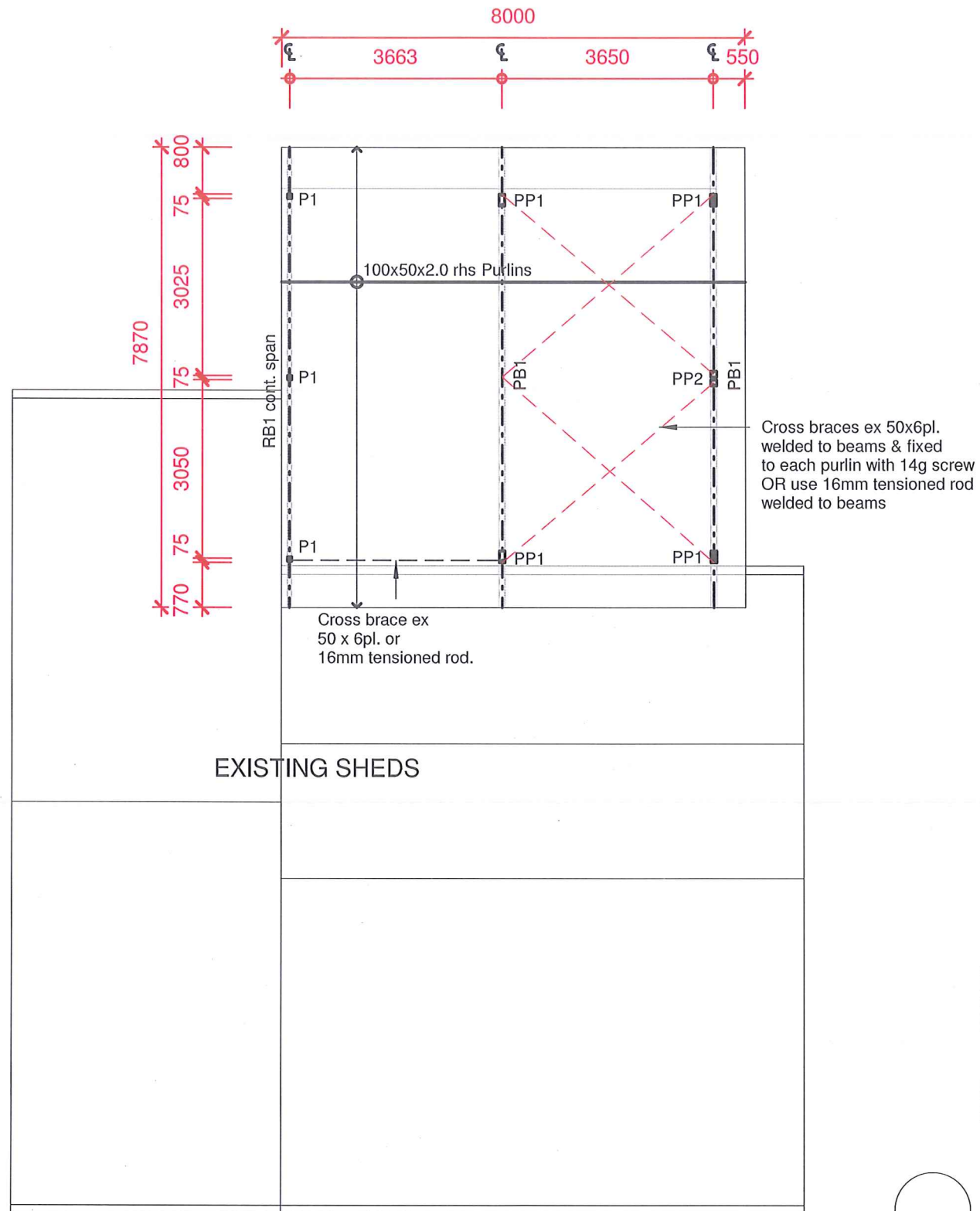

Cross braces ex 50x6pl. welded to beams & fixed to each purlin with 14g screw OR use 16mm tensioned rod welded to beams

Cross brace ex 50 x 6pl. or 16mm tensioned rod.

- P1 75x4.0 shs Post
- PP1 150x100x4.0 Portal Post
- PP2 2x100x4.0 Portal Posts
See Section 3
- RB1 125x75x4.0 rhs Roof Beam
- PB1 150x100x4.0 rhs Portal Beam

○ Roof Legend
1 : 50

① Roof Frame Plan
1 : 100

STRUCTURAL DETAILS
ADEQUATE AS CERTIFIED

[Signature]

RODGERS CONSULTING ENGINEERS
H P Rodgers RPEQ 7859

JOB NO: 260131	DATE: 17/04/2026
-------------------	---------------------

RODGERS Consulting Engineers Ph. 40 519 466	These drawings are copyright and must not be copied or retained. Do not scale from drawings. The contractor & sub-contractors are to verify all dimensions before commencing work and bring to the attention of the designer any discrepancies they may find.	R & M Duncan 256 Bamboo Ck. Rd. Bamboo Proposed Shed Extension.	LAWSON DESIGN PH. 40 532 058 M. 0412 592 900 P.O. Box 349 EDGE HILL 4870 Building Designers Assoc. Qld. QBSA no. 24590	Site Classification TBC Design Wind Speed C2	Date 17/4/26 Amendments	JOB No. 2502 DWG. No. 06
--	---	--	--	---	--------------------------------------	---